



September 2009

FREQUENTLY ASKED QUESTIONS

Wiring Rules

The new edition of the Australian/New Zealand Standard for Wiring Rules (AS/NZS 3000:2007) was released in November 2007 and revised by Amendment 1 in July 2009.

Produced by the joint Standards Australia/Standards New Zealand Committee EL-001, the revised edition expands on issues relating to electrical installations, improves safeguards and, addresses the needs and expectations of stakeholders.

The amended edition of the Wiring Rules Standard is available in Australia from Standards Australia's distributor of Australian Standards, SAI Global at www.saiglobal.com/shop or 131 242 and in New Zealand from Standards New Zealand at www.standards.co.nz

The following Frequently Asked Questions (FAQs) and answers have been developed by the committee responsible for the Wiring Rules (2007) and Amendment 1 to explain some of the issues which have been raised by users of the Standard.

**FAQ 001/2009: AS/NZS 3000:2007—CLAUSE 1.9.3
1.9.3 ALTERATIONS, ADDITIONS AND REPAIRS**

Question 001/2009. When carrying out alterations and additions to electrical installations what requirements, other than those directly associated with the work, are required?

Answer. If the alteration or addition is an improvement to the electrical installation protection techniques and satisfies Clause 1.9.3 Items (a) and (b), and Clause 2.6.3.4 then no additional work is required.

NOTE: Examples are provided below for specific questions and answers to Clause 1.9.3.

**FAQ 002/2009: AS/NZS 3000:2007—CLAUSE 1.9.3
1.9.3 ALTERATIONS, ADDITIONS AND REPAIRS**

Question 002/2009. If an existing item of electrical equipment is relocated, what requirements of AS/NZS 3000:2007 apply?

Answer. If the only work is the relocation of the electrical equipment using existing conductors the requirements that would apply are the -

- (a) fixing and location of the electrical equipment; and
- (b) mechanical protection for the cables in the new location.

However, if cables are renewed or extended, all the appropriate requirements such as mechanical protection, size, overcurrent protection and RCD protection are to be applied.

**FAQ 003/2009: AS/NZS 3000:2007—CLAUSE 1.9.3
1.9.3 ALTERATIONS, ADDITIONS AND REPAIRS**

Question 003/2009. Is the replacement of an item of electrical equipment considered a repair?

Answer. Yes. Provided it does not adversely affect the electrical installation.

**FAQ 004/2009: AS/NZS 3000:2007—CLAUSE 1.9.3
1.9.3 ALTERATIONS, ADDITIONS AND REPAIRS**

Question 004/2009. If an additional item of electrical equipment is added to a circuit, what requirements of AS/NZS 3000:2007 would apply?

Answer. All the requirements deemed appropriate apply, including the following:

- (a) Any additional conductors must be of an appropriate size, have the correct relationship with a circuit protective device, and have mechanical protection.
- (b) Conditions on voltage drop must be met.
- (c) Conditions on fault-loop impedance and disconnection times must be met.
- (d) Compliance with Clause 2.2.1 on circuits.
- (e) Compliance with Clause 2.6 on additional protection by RCDs

The exceptions to installing RCDs in accordance with Clause 2.6.3.5 apply.

**FAQ 005/2009: AS/NZS 3000:2007—CLAUSE 1.9.3
1.9.3 ALTERATIONS, ADDITIONS AND REPAIRS**

Question 005/2009. What requirements apply when a new circuit is installed?

Answer. All the requirements of AS/NZS 3000:2007 apply.

**FAQ 006/2009: AS/NZS 3000:2007—CLAUSE 3.7.2.1.2
3.7.2.1.2 ELECTRICAL CONNECTIONS—Connection methods—General**

Question 006/2009. What factors need to be considered when connecting aluminium conductors?

Answer. It is recommended that literature provided by manufacturers of aluminium cables and components designed for the connection of aluminium conductors be consulted to determine the appropriate techniques to use.

Some of the techniques used in the jointing or termination of aluminium conductors are as follows:

- (a) The use of purpose designed bi-metallic cable lugs and other connection devices.
- (b) Welding, which may be used for solid or stranded conductors.
- (c) Soldering of solid conductors, utilizing special solders which scratch remove the aluminium oxide and tin the conductors.
- (d) Soldering of stranded conductors, utilizing special fluxes to remove the aluminium oxide and the use of solder basting techniques to tin the conductors.
- (e) Crimping, indenting or compression of solid or stranded conductors using cable lugs or ferrules made of aluminium and designed for the purpose.
- (f) Removal of the aluminium oxide from contact surfaces by applying an oxide-inhibiting compound and leaving it in place to prevent the ingress of moisture and air to the completed joint.
- (g) Bolting or clamping terminations using aluminium alloy bolts and nuts that expand or contract at the same rate as the conductor and cablelug.
- (h) Using spring cup washers of the 'Belleville' type, which when properly selected will compensate for any differential expansion of the aluminium conductor and other metals in the joint.
- (i) Tunnel type terminals specifically designed to evenly distribute stress on conductors.

Consideration needs to be given to the following:

- (i) Removal of the aluminium oxide film, which prevents good electrical contact, from the conductors.
 - (ii) Avoiding contact with dissimilar metals that may initiate galvanic action
 - (iii) The different coefficient of linear expansion of aluminium and other metals that, when connected together may over time, due to expansion and contraction, result in loose connections.
 - (iv) The relative softness of aluminium, which when compressed may cause the metal to 'flow' away from the connection resulting in a high resistance connection.
-

**FAQ 007/2009: AS/NZS 3000:2007—CLAUSE 3.8 & TABLE 3.4 & CLAUSE 5.2.2
3.8 IDENTIFICATION
TABLE 3.4 CONDUCTOR COLOURS FOR INSTALLATION WIRING
5.2.2 EARTHING FUNCTIONS—Functional earthing (FE)**

Question 007/2009. If an RCD is provided with a functional earthing conductor (typically coloured white or pink), may this conductor be connected to an earthing terminal/connection or bar?

Answer. Yes. The purpose of the conductor is to allow a return path for the electronic circuit, if the neutral is disconnected, to ensure the RCD still operates correctly. The conductor does not perform a protective earth function.

FAQ 008/2009: AS/NZS 3000:2007—CLAUSE 6.3.4 and CLAUSE 7.5

6.3.4 SWIMMING POOLS, PADDLING POOLS AND SPA POOLS OR TUBS - Selection and installation of electrical equipment

7.5 EXTRA-LOW VOLTAGE ELECTRICAL INSTALLATIONS

Question 008/2009. May the power supply for electrical equipment, such as luminaires, intended for installation in Zone 0 be designed for an output voltage above the nominal voltage to allow for a voltage drop in the cables between the power supply and the equipment?

Answer. No. The power supply is to be designed for the nominal voltage of 12 V a.c. or 30 V ripple-free d.c.

FAQ 009/2009: AS/NZS 3000:2007—CLAUSE 1.7 & CLAUSE 2.9.3.1

1.7 SELECTION AND INSTALLATION OF ELECTRICAL EQUIPMENT

2.9.3.1 Construction—*Access to live parts*

Question 009/2009. What means could be used to identify an electrical switchboard or other electrical equipment that contains live parts in locations where additional attention should be given to the removal of covers and the like.

Answer. Australian Standard 1319—1994, *Safety signs for the occupational environment* specifies requirements for the design and use of safety-signs intended to warn of electrical and other occupational hazards. Table B3, Sign Number 447, is the symbolic electrical shock risk sign.



The shock risk sign's effectiveness should be reinforced with a DANGER sign that, with an additional message of appropriate words, alerts persons to a particular life threatening hazard.

FAQ 010/2009: AS/NZS 3000:2007—CLAUSE 5.3.5.2, CLAUSE 5.4.5 & CLAUSE 5.5.3.5

5.3.5.2 EARTHING SYSTEM PARTS—MEN Connection—*Size*

5.4.5 EARTHING OF EQUIPMENT—*Conductive supports for aerial conductors*

5.5.3.5 EARTHING ARRANGEMENTS—*Particular methods of earthing—Unprotected consumers mains*

Question 010/2009. Why are bonding conductors connected to exposed conductive parts such as switchboard surrounds and riser brackets etc and the MEN connection associated with unprotected consumers mains required to be of a cross-sectional area not less than the main neutral conductor? When can the electrical installation earthing system be used?

Answer. In the case of unprotected consumers mains, any conductor that forms part of the earth fault loop for the unprotected consumers mains must have a capacity not less than that of the main neutral conductor. Short circuit of an unprotected active conductor to a switchboard surround, riser bracket etc will cause the bonding conductor to carry the maximum fault current available through those consumers mains.

A bonding conductor of equivalent capacity to the main neutral conductor would -

- (a) provide a reasonable chance for any upstream short circuit network system protective devices (i.e. at distribution transformer) to operate; and
- (b) limit the amount of damage to the consumers earthing system; and
- (c) maintain the integrity of the MEN connection.

The electrical installation earthing system can be used where -

- (i). the switchboard/meter enclosure, riser bracket etc is earthed by a bonding conductor connected to the main neutral conductor in accordance with Clause 5.5.3.5(a); or
- (ii). double insulation is maintained to the service protective device on the switchboard/meter enclosure.

In these situations, the MEN connection is not required to carry earth fault current arising from the consumers mains and hence may have a cross-sectional area not less than the main earthing conductor in accordance with Exception (b) or (c) to Clause 5.3.5.2.

Examples:

When double insulation of consumers mains is maintained to the service protective device on the switchboard/meter enclosure, then the enclosure may be earthed to the electrical installation earthing system with a protective earthing conductor sized in accordance with Clause 5.3.3.1.2 for the largest single insulated active conductor within the enclosure. See Figure 10.1.

Figure 10.2 shows an example using unprotected consumers mains having sheathing that is not maintained to the service protective device, with the enclosure earthed by direct connection to the main neutral conductor. In this example the MEN connection does not form part of the earth fault loop for the enclosure.

Figure 10.3 shows an example using unprotected consumers mains without sheathing, with the enclosure earthed by connection to the earth bar. In this example the MEN connection must have a cross-sectional area not less than that of the main neutral conductor in accordance with the second paragraph of Clause 5.3.5.2 as it forms part of the earth fault loop for the enclosure.

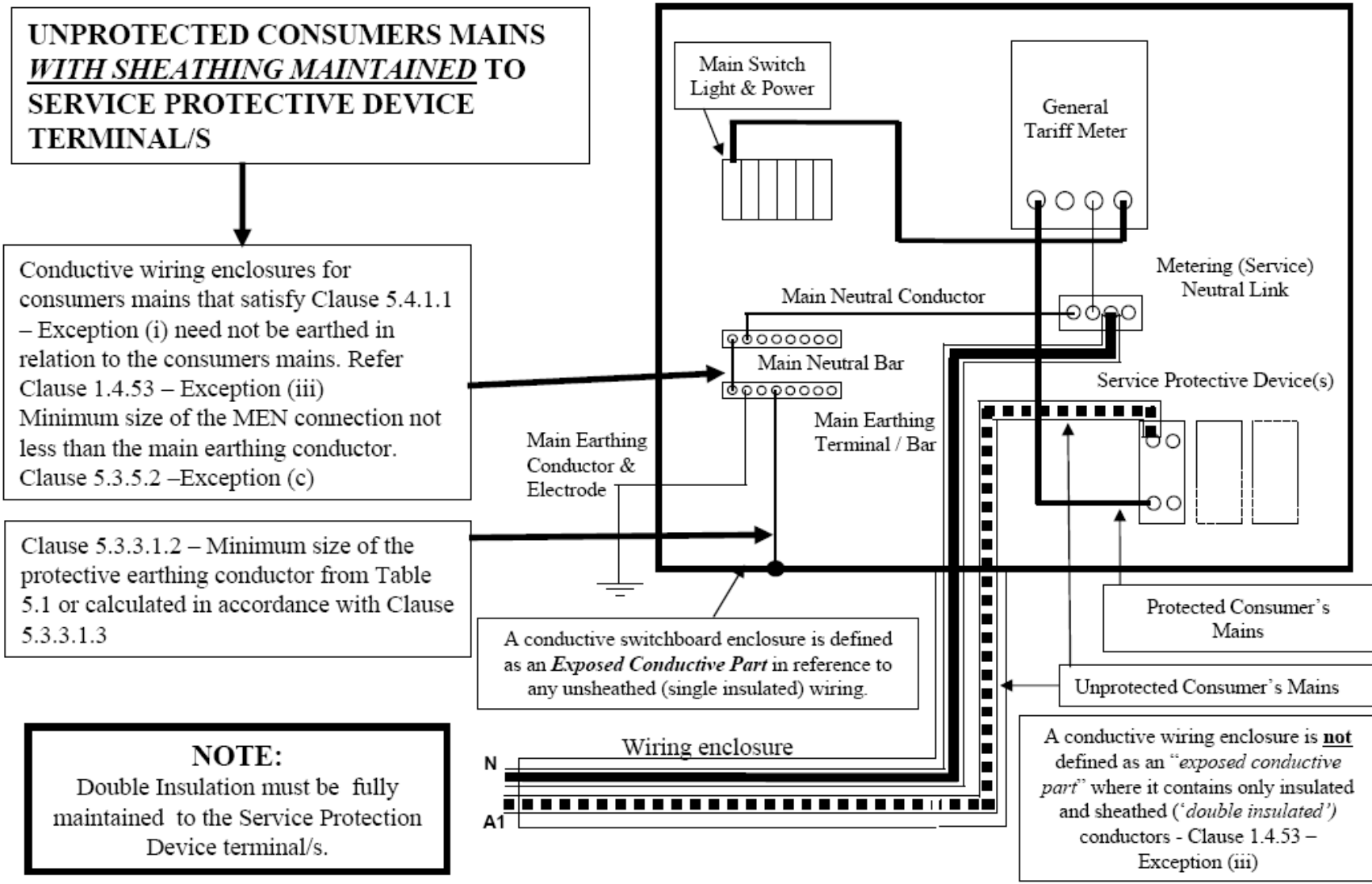

FIGURE 10.1

UNPROTECTED CONSUMERS MAINS WITH *SHEATHING NOT MAINTAINED* TO SERVICE PROTECTION DEVICE TERMINAL/S

Clause 5.3.5.2 - Exception (c)
Minimum size of the M.E.N connection not less than the main earthing conductor

Clause 5.5.3.5 (a) Any exposed conductive parts associated with unprotected consumers mains shall be earthed by a conductor having a cross sectional area not less than the main neutral conductor.

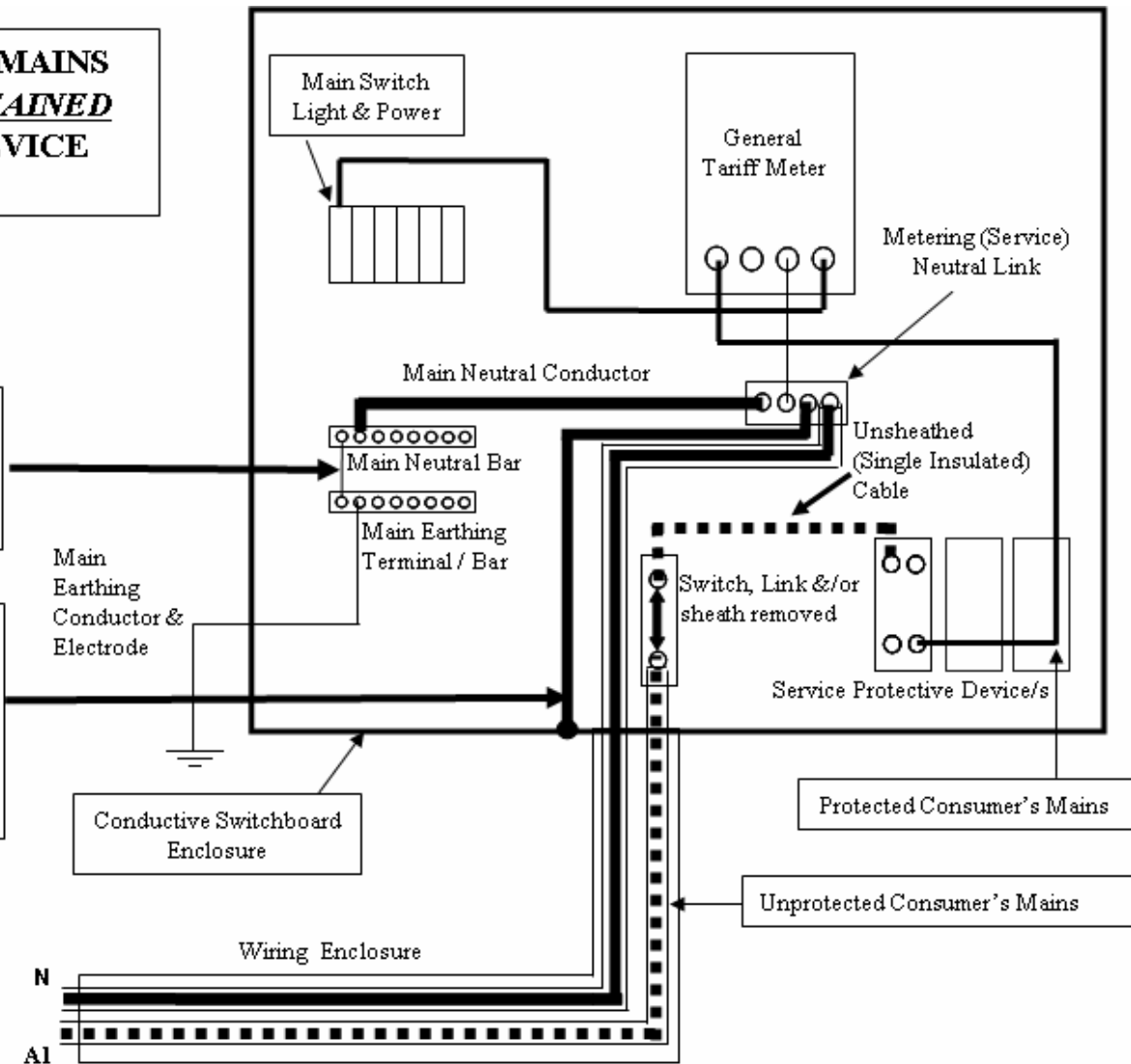

FIGURE 10.2

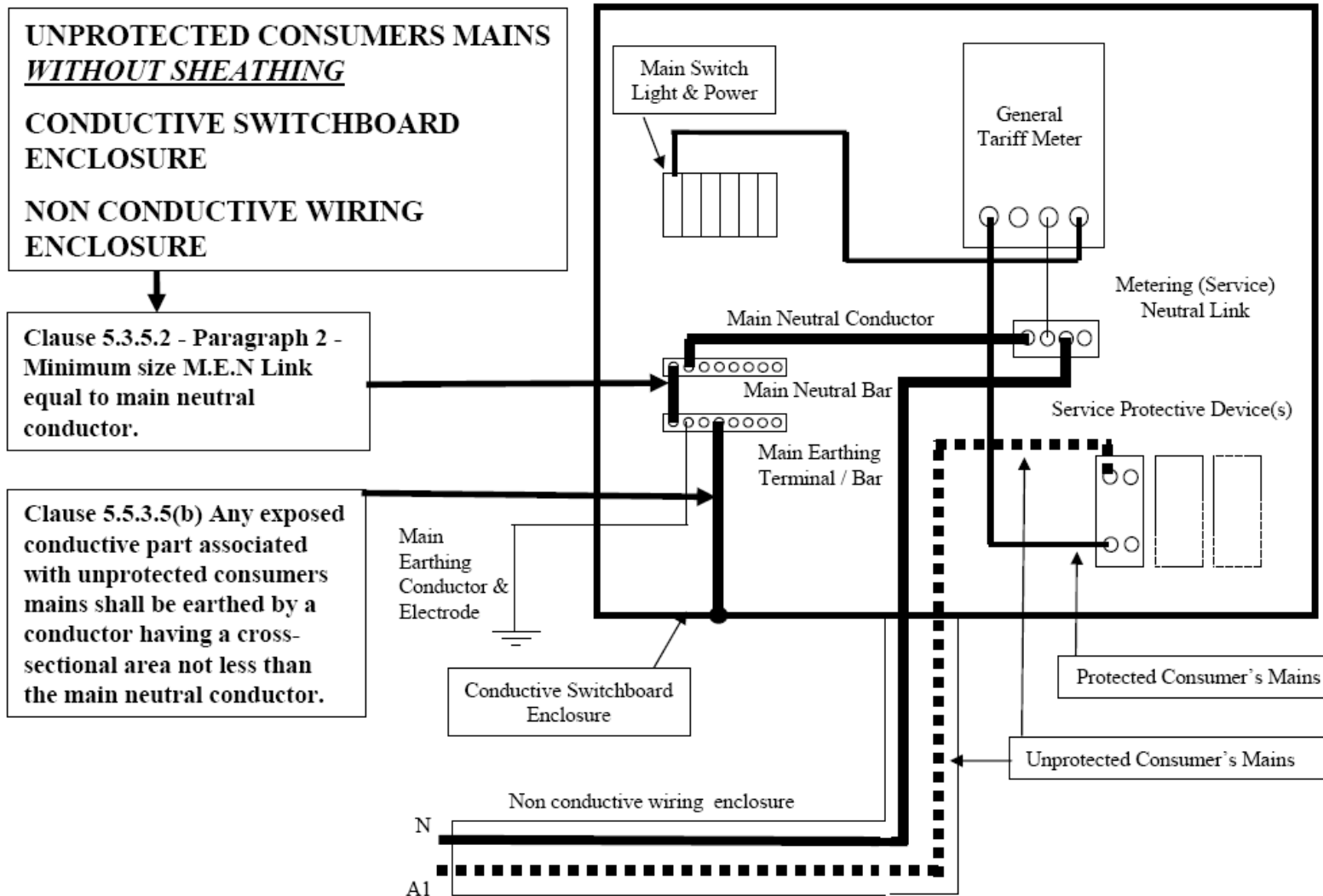

FIGURE 10.3

FAQ 011/2009: AS/NZS 3000:2007—CLAUSE 5.6.2.6 & CLAUSE 6.3.3.2
 5.6.2.6 EQUIPOTENTIAL BONDING—Arrangement—*Swimming and spa pools*
 6.3.3.2 SWIMMING POOLS, PADDLING POOLS AND SPA POOLS OR TUBS—Protection against electric shock—*Supplementary equipotential bonding*

Question 011/2009. Do extraneous conductive parts such as a pool fence, which are located inside Zone 1 or Zone 2 surrounding a pool, but beyond arm’s reach, require equipotential bonding?

Answer. No. Clause 6.3.3.2 requires extraneous conductive parts within Zone 1 or Zone 2 to be bonded in accordance with Clause 5.6.2.6. Clause 5.6.2.6 does not require bonding of such extraneous conductive parts unless they are within arm’s reach of the pool’s edge.



FAQ 012/2009: AS/NZS 3000:2007—CLAUSE 5.5.3.5
 5.5.3.5 EARTHING ARRANGEMENTS—Particular methods of earthing—*Unprotected consumers mains*

Question 012/2009. What are considered to be unprotected consumers mains in accordance with AS/NZS 3000:2007?

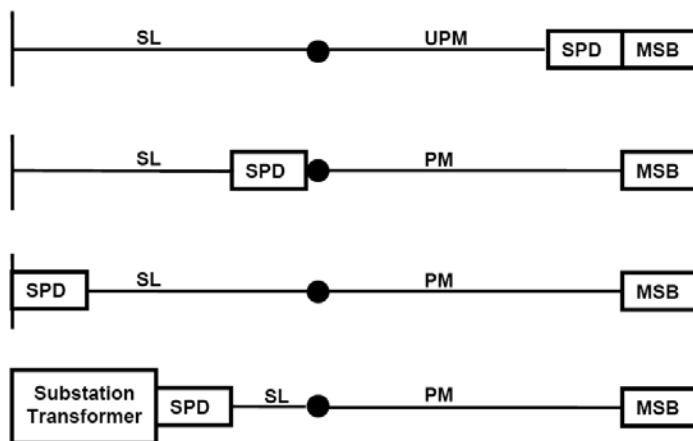
Answer. Unprotected consumers mains are those that are not protected by a Service Protective Device (SPD) as shown in the following sketch.



Legend

- | | | |
|---|---|---------------------------------|
|  | Service protective device – provides short-circuit protection but not necessarily overload and earth fault protection | |
|  | Main switchboard | SL Service line |
|  | Point of supply | PM Protected consumers mains |
| | | UPM Unprotected consumers mains |

FAQ 013/2009: AS/NZS 3000:2007—CLAUSE 3.11 AND TABLE 3.5
3.11 UNDERGROUND WIRING SYSTEMS
TABLE 3.5 UNDERGROUND WIRING SYSTEM CATEGORIES

Question 013/2009. What distinguishes a neutral screened cable suitable to be buried direct in the ground without mechanical protection from other neutral screened cables?

Answer. A neutral screened cable with a sheath of at least 3.2 mm thickness, marked "UNDERGROUND" and complying with AS/NZS 4961.

FAQ 014/2009: AS/NZS 3000:2007—CLAUSE 1.9.3
1.9.3 MEANS OF COMPLIANCE - Alterations, additions and repairs

Question 014/2009. When an addition is made to a circuit protected by a semi-enclosed rewirable fuse, under what conditions should the semi-enclosed rewirable fuse be replaced?

Answer.

(a) *Short-circuit protection*

The semi-enclosed rewirable fuse should be replaced with another type of protective device when the prospective short-circuit current is greater than 1 kA (e.g. change in distribution network).

(b) *Overload current protection*

The semi-enclosed rewirable fuse should be replaced with another type of protective device when the marked current rating of the fuse or fuse element is greater than 69% of the continuous current-carrying capacity of the cable (*I_z*).

(c) *Degradation of the fuse base and/or carrier*

The semi-enclosed rewirable fuse should be replaced with another type of protective device when there is a visible significant deposition of carbon and/or copper on the fuse base or carrier.

FAQ 015/2009: AS/NZS 3000:2007—CLAUSE 1.4.63
1.4.63 Live part

Question 015/2009. When a circuit is isolated by means of an isolating switch acting in all live (active and neutral) conductors is the neutral conductor downstream of the switch regarded as live?

Answer: No.

FAQ 016/2009: AS/NZS 3000:2007 – CLAUSE 2.6.3.2
2.6.3.2 Where additional protection is required – Other electrical installations

Question 016/2009. Are circuits supplying only exit signs and emergency lighting required to be protected by an RCD?

Answer: No. They would be included in Exception 5 of this Clause since disconnection of the circuit by an RCD could cause a danger greater than earth leakage current.

FAQ 017/2009: AS/NZS 3000:2007—CLAUSE 2.6.3.4 & CLAUSE 2.6.3.1

2.6.3.4 Alterations, additions and repairs

2.6.3.1 Residential electrical installations

Question 017/2009. Does the addition of a combination fan, light and heater unit, an exhaust ceiling fan or a ceiling sweep fan (with an unswitched socket outlet) to an existing lighting circuit without RCD protection need to be protected by an RCD?

Answer: No. For the purposes of Clause 2.6.3.1 combination fan, light and heating units, exhaust fans and ceiling sweep fans are all regarded as lighting points.

FAQ 018/2009: AS/NZS 3000:2007—CLAUSE 1.7.2 & CLAUSE 2.9.2.5

1.7.2 INSTALLATION WORK PRACTICE

2.9.2.5 LOCATION OF SWITCHBOARDS- *restricted locations*

Question 018/2009. Do the provisions of Clause 2.9.2.5 (c) apply to a switchboard installed within a service duct or shaft that provides access to building services such as telecommunications, data, power and similar in a multi-storey building?

Answer. No. For the purposes of Clause 2.9.2.5 (c) a service duct or shaft in a multi-storey building is not regarded as a cupboard or similar enclosure.

The location of a switchboard installed in a service duct or shaft is required to satisfy Clause 2.9.2.2 and access to the service duct or shaft should be restricted to authorized persons.

FAQ 019/2009: AS/NZS 3000:2007—CLAUSE 3.6.2

3.6.2 VOLTAGE DROP – Value

Question 019/2009. Is the 7% voltage drop applicable to rural type installation (e.g. homestead, shearing shed, other accommodation, irrigation pumps, etc)?

Answer. Yes. Provided the transformer is dedicated to the installation

FAQ 020/2009: AS/NZS 3000:2007—CLAUSE 3.9.7.1.2

3.9.7.1.2 Particular requirements *Consumers mains - Unprotected*

Question 020/2009. In addition to the wiring systems identified in items (i) to (iv), under what conditions would an unenclosed, insulated and sheathed cable be permitted as unprotected consumers mains for installations?

Answer. Subject to any additional requirements or restrictions of the electricity distributor, the following installation conditions for an insulated and sheathed cable are deemed to minimise the risk of short-circuit:

(a) Installed in areas that would not be subject to mechanical damage (see Clause 3.9.4), for example –

- (i) supported more than 50mm from surfaces in a roof space that may be penetrated by nails, screws or drills and in a location not subject to damage by access within the roof space
 - (ii) run in double brick or brick veneer wall cavities; or
 - (iii) supported by cable trays or ladders or at the point of attachment at a height of not less than 2.5m from the ground, floor or platform (out of arms reach);
- and,

(b) Additional mechanical protection of the cable, by insulating, enclosing or installing barriers, at any points along the mains likely to be damaged due to movement, for example where the cable passes through or contacts abrasive building materials or for any other reason.

Additional requirements may be applied by various States in Australia.

FAQ 021/2009: AS/NZS 3000:2007 – CLAUSE 1.5.14, CLAUSE 3.9.4 & CLAUSE 3.9.4.4

1.5.14 Protection against external influences

3.9.4 Protection against mechanical damage

3.9.4.4 Protection methods

Question 021/2009. What types or methods of protection are regarded as adequate to prevent mechanical damage in accordance with Clause 3.9.4?

Answer. The provisions of Clause 3.9.4 are intended to protect wiring systems installed in locations where they may reasonably be expected to be subject to mechanical damage such as a screw or nail penetrating the surface of the structure containing the electrical installation.

The method of protection of the wiring system may be any one of the three detailed in Clause 3.9.4.4.

These three methods are:

Clause 3.9.4.4 (a) that requires prevention of mechanical damage to the wiring system.

The form of mechanical protection must be such as would **prevent** a screw or nail etc penetrating the wiring system and should take into account the material and type of wall structure together with the type of tool likely to be used to insert a screw or nail into the surface (i.e. solid brick, plasterboard lining, concrete slab etc).

If there remains a risk that the wiring system could be penetrated after the installation of the mechanical protection, the risk has not been prevented and either sub-clause (b) or (c) must be applied.

Clause 3.9.4.4 (b) that requires the use of an armour, screen, covering or enclosure that is earthed to ensure that in the event of penetration of the wiring system the circuit protective device will operate.

Metallic barriers, such as sheet metal, wall boxes and the like shall be earthed by means of a conductor having a size not less than that required for the largest associated circuit.

Clause 3.9.4.4 (c) that requires the use of an RCD to provide additional electrical protection that obviates the need for the forms of additional mechanical protection detailed in (a) and (b).

It should also be noted that Clause 3.3.2.6 requires wiring systems to be arranged to minimize the risk of mechanical damage. Therefore suitable location of the system such that the risk does not exist

should always be the first choice. For example, a wiring system installed within the cavity of a double brick cavity wall would not be considered at risk of mechanical damage.

Wiring systems installed in an internal cavity wall where there is a cupboard or similar enclosure permanently installed in such a manner as to preclude the risk of penetrating the wall cavity would not be regarded as being at risk provided that the wiring is more than 50mm from the opposite (exposed) surface of the wall. For example, a cupboard arranged to form a duct of at least 50mm between the wall and the rear of the cupboard such as one above a wall oven arranged to provide for the dissipation of heat generated by the oven. (The 50mm could include the thickness of the wall surface.)

FAQ 022/2009: AS/NZS 3000:2007—CLAUSE 3.12.3.2

3.12.3.2 Clearances – Safety warnings

Question 022/2009: What are suitable devices or notices for safety warnings near aerial conductors?

Answer: The warning notice should be located on each electricity pole. The signs should have the same dimensions and colours as those listed in AS 1319. Some examples of signs are given below for use on waterways. For general use the yellow diamond could be replaced by the danger sign (below) and the wording suitably modified.

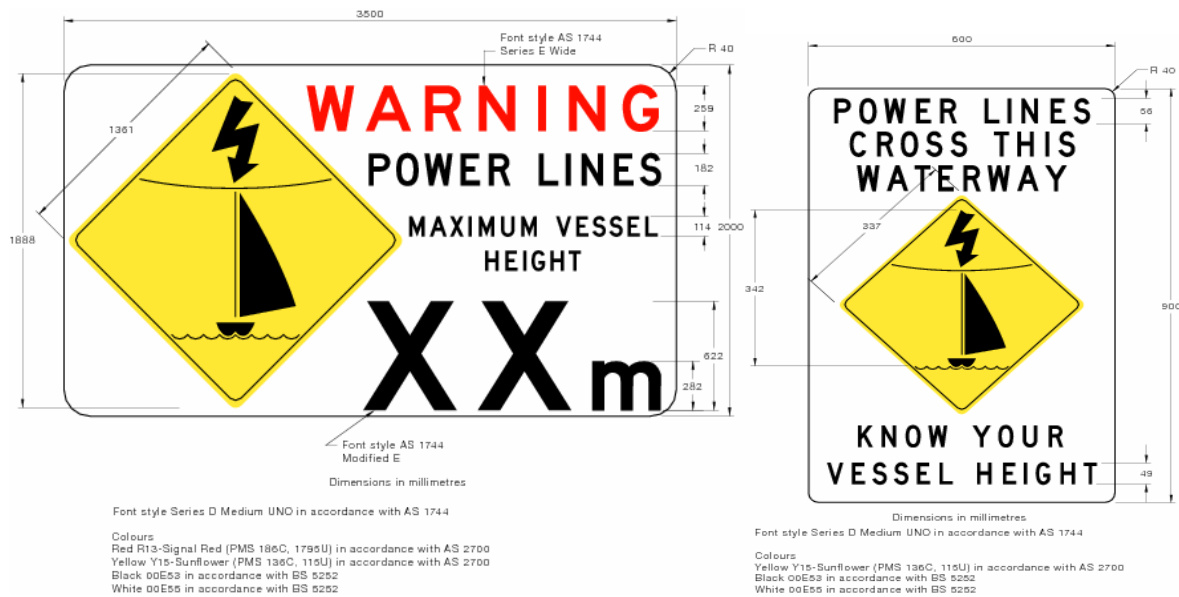

**FAQ 023/2009: AS/NZS 3000:2007 – CLAUSE 3.11.5 CLAUSE 3.9.8.4 TABLE 3.7
3.11.5 SPACING FROM OTHER UNDERGROUND SERVICES**

3.9.8.4 Proximity to non-electrical services

TABLE 3.7 MINIMUM SEPARATION OF UNDERGROUND SERVICES

Question 023/2009: Are the separation distances in Table 3.7 only required for services using metallic pipelines?

Answer: No. The separation between services (Column 2) applies to all situations (metallic and insulating pipes). The distance from the earth electrode (Column 3) applies only to metallic pipelines.

FAQ 024/2009: AS/NZS 3000:2007 – CLAUSE 5.6.2.5

5.6.2.5 EQUIPOTENTIAL BONDING – Arrangement – Showers and bathrooms

Question 024/2009:

- (a) Is it a requirement for the connection of the equipotential bonding conductor to be accessible?
- (b) Is it acceptable to run the conductive reinforcing system bonding conductor to a part of the equipotential bonding system outside of the room involved?
- (c) Is it acceptable, where the conductive reinforcing system is electrically continuous, for the conductive reinforcing system to be exposed above the slab, in one location only, and earthed to the earth bar within a switchboard, if the connection within the switchboard is suitably labelled?
- (d) In instances where there are multiple dwellings on one slab on the same level, is it acceptable, where the conductive reinforcing system is electrically continuous, for the conductive reinforcing system to be exposed above the slab, in one location only, and to be connected to the earth bar within the switchboard that provides electricity supply to the dwellings?

Answer:

- (a) No. The requirements of the clause are similar to the requirements for equipotential bonding in the case of swimming and spa pools where the equipotential bonding connection is not specifically required to be accessible. (See Clause 5.6.2.6.)
- (b) Yes. The bonding conductor may be connected to any part of the earthing system.
- (c) Yes
- (d) Yes

FAQ 025/2009: AS/NZS 3000:2007 – CLAUSE 5.6.2.5

5.6.2.5 Arrangement – Showers and bathrooms

Question 025/2009:

What methods may be used to connect the reinforcing within the concrete floor to the earthing system?

Answer: Several commercial products are available to enable effective equipotential bonding to the reinforcing mesh. One option (see picture below) is to have a galvanised or stainless steel rod that is tied to the electrically continuous steel reinforcing mesh that includes the shower or bathroom, bent up in the wall cavity below the meter position. A minimum 4mm equipotential bonding conductor is then connected between the main earthing conductor, bar or link located at the main switchboard and the rod. Alternatively the bonding conductor can be connected to any other part of the earthing system.



Whilst the bonding does not rectify any high resistance in the PEN conductor, it does bond the conductive floor to any other conductive material or equipment within the bathroom and prohibit any voltage differences that might otherwise arise.

FAQ 026/2009: AS/NZS 3000:2007—CLAUSE 2.9.2.2

2.9.2.2 Location of switchboards – Accessibility and emergency exit facilities

Question 026/2009: Can the clearance of 600mm be achieved by removing the hinged door of a switchboard?

Answer: No. However, unhinged removable panels would satisfy the requirements

FAQ 027/2009: AS/NZS 3000:2007—CLAUSE 6.2.2

6.2.2 BATHS, SHOWERS AND OTHER FIXED WATER CONTAINERS – Classification of zones

Question 027/2009: When the fixed shower plumbing connection is located above 2.5 m height does it remain in Zone 1?

Answer: Yes. See classification of zones in Clause 6.2.2.1(b)(vi) and 6.2.2.1(c)(v)

FAQ 028/2009: AS/NZS 3000:2007—CLAUSE 2.9.5.2

2.9.5.2 Equipment identification – *Relationship of electrical equipment*

Question 028/2009: What are the minimum marking requirements to satisfy this clause?

Answer: The protective devices for the circuits should be marked according to what they control and protect (eg CB1 - lights), and the geographical location of the equipment should be stated. (eg lighting - north western area of main office).

This information, in the English language, should be on the switchboard or in the form of a permanently attached legend immediately adjacent to the switchboard.

FAQ 029/2009: AS/NZS 3000:2007—CLAUSE 3.10.3.1

3.10.3 Installation of wiring enclosures – *General*

Question 029/2009: May a wiring system be placed within a concrete path?

Answer: No. A wiring enclosure placed within a concrete path does not satisfy the requirements for underground wiring and is not considered to be 'safe and sound practice' and does not provide adequate protection.

FAQ 030/2009: AS/NZS 3000:2007—CLAUSE 2.9.2.2(c)(ii)

2.9.2.2(c) Location of switchboards – *Accessibility and emergency exit facilities*

Question 030/2009: What are the requirements for 'sufficient exit facilities' for large switchboards?

Answer: Normally the requirements would include two exits from the switchboard spaced well apart to allow a person to leave the vicinity of a switchboard under emergency conditions. However, where a clear space of three (3) metres is provided around the switchboard and its equipment, including switchboard doors, in all normal positions of operating, opening and withdrawal, only one exit need be provided. Note that three adjoining one metre switchboards are viewed as a three metre switchboard for the purposes of this clause.

FAQ 031/2009: AS/NZS 3000:2007—CLAUSE 5.4.6.2

5.4.6.2 Structural metalwork including conductive building materials – *Domestic electrical installations*

Question 031/2009: Is it necessary to earth individual lintels, posts, metal window frames and steel trusses mounted on timber walls?

Answer: No. However, shrouding may be required where terminations to electrical equipment cannot maintain double insulation when they are in close proximity to conductive building materials. (See Clause 5.4.6.1)

FAQ 032/2009: AS/NZS 3000:2007—CLAUSE 2.6.3.4

2.6.3.4 Where additional protection is required – *Alterations, additions and repairs*

Question 032/2009: Can a socket–outlet added to an existing circuit be protected by an RCD incorporated into the socket–outlet?

Answer: Yes, although it is preferable to locate the RCD in the switchboard to protect the complete circuit rather than installing an RCD that protects only the individual socket-outlet.

Ends.